



# PLANNING & APPLICATION UNI-RIVET MANUAL

## Disclaimer

The information in this manual is by no means exhaustive. This document has been developed to assist with the correct preparation and installation of EQUITONE panels. For full and detailed information about storage, handling, preparation, and design and installation requirements of EQUITONE, refer to EQUITONE Planning and Application Guide and other available EQUITONE relevant technical documents.

Refer to EQUITONE Material Safety Data Sheets (MSDS) or Safety Information Sheets (SIS) for more information about health and safety, including common hazards associated with working with EQUITONE, and measures to minimize risk.

The information in this document is correct at the time of issuing. However, due to our committed program of continuous material and system development we reserve the right to amend or alter the information contained in this document without prior notice. Please contact your local EQUITONE sales organization or visit [www.equitone.com](http://www.equitone.com) to ensure you have the most current version.

This document is supplied in good faith and no liability can be accepted for any loss or damage resulting from its use. Images and construction details contained in this document are not to a specific scale, and are indicative and for illustration purposes only.

This document is protected by International copyright laws. Reproduction and distribution in whole or in part without prior written permission is strictly prohibited. EQUITONE and logos are trademarks of Etex NV or an affiliate thereof. Any use without authorization is strictly prohibited and may violate trademark laws.

# TABLE OF CONTENTS

## TOOLS & ACCESSORIES

Page 3

## STORAGE & HANDLING

Page 4-6



## PANEL CUTTING

Tools, Page 7

Panel cutting, Page 8

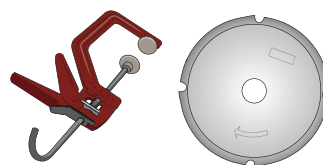

## PANEL EDGE TREATMENT

Tools, Page 9

Panel edge treatment, Page 10-12

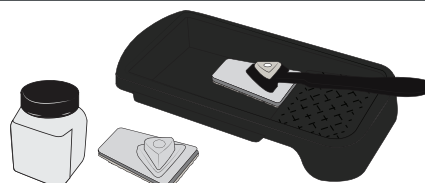

## PANEL DRILLING

Tools, Page 13

Panel drilling, Page 14-15

Panel drilling EQUITONE [linea], Page 16-17



## UNI-RIVET FIXING

Tools, Page 18

UNI-Rivet fixing, Page 19-22

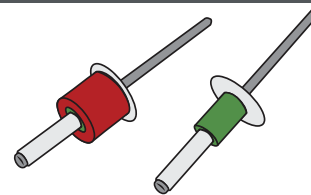

## VENTILATION

Page 23



## INSTALLATION

Page 24-26



# TOOLS & ACCESSORIES

Centralizing Tool

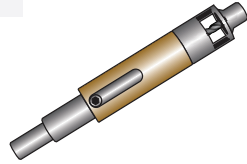

EQUITONE  
Care Toolkit

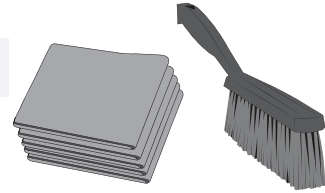

Centralizing Tool  
Replacement  
drill bit  
Ø4.1mm

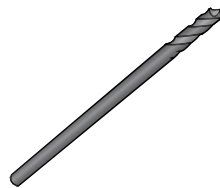

\*LUKO Edge  
Sealer



Rivet Setting  
Tool



\*LUKO Applicator

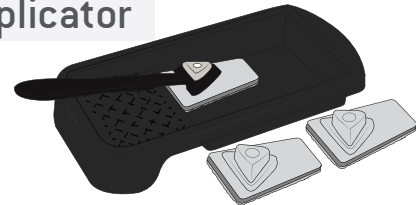

EQUITONE  
Fiber Cement  
Saw Blade

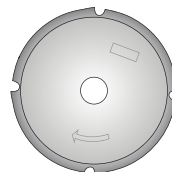

UNI-Rivet

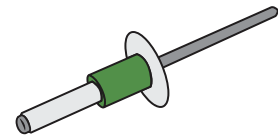

EQUITONE  
Fiber Cement  
Drill Bit  
Ø11mm

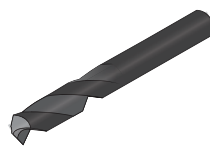

UNI-Rivet  
Red/STOP  
Spacer



EQUITONE  
[linea]  
Milling Tool  
Ø11mm



Foam Tape

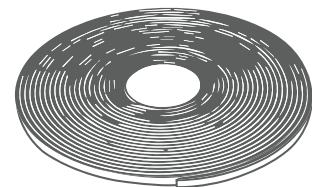

Aluminum  
Horizontal  
Joint Profile

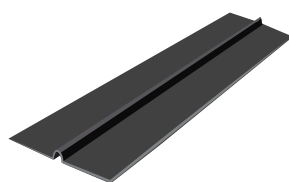

Aluminum  
Perforated  
Closure

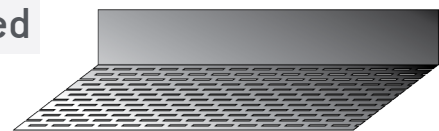

\*Only for EQUITONE [natura] PRO & [natura]



# STORAGE & HANDLING

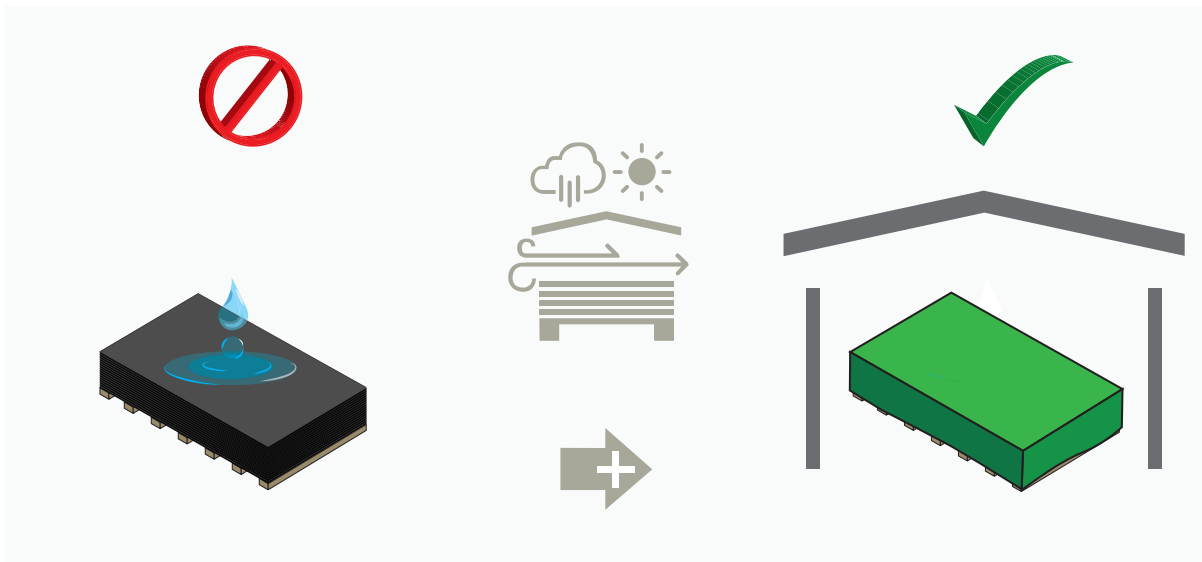
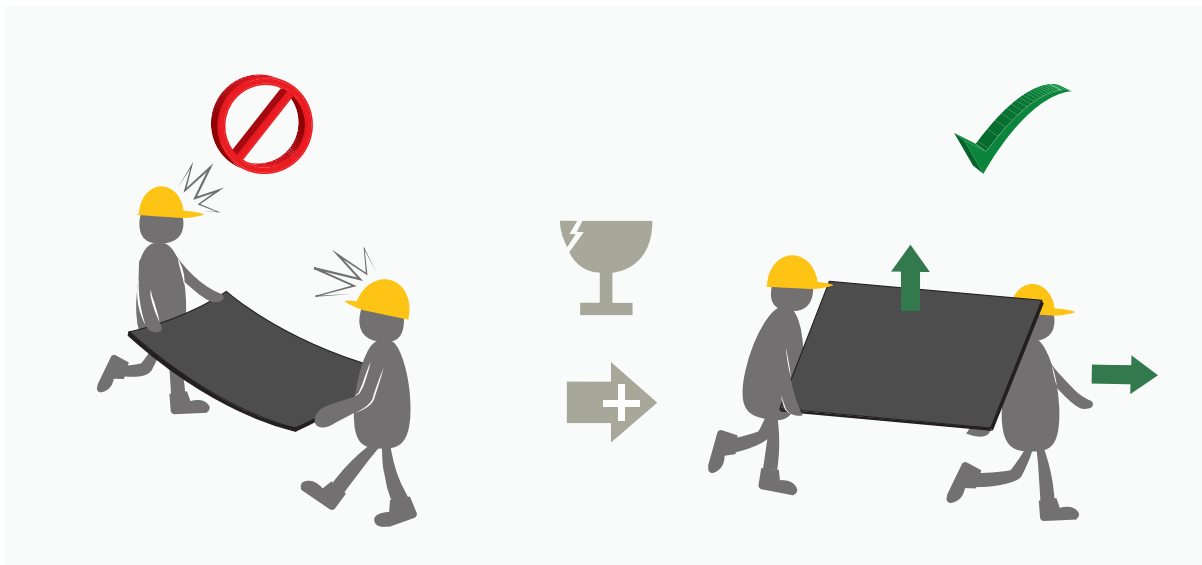
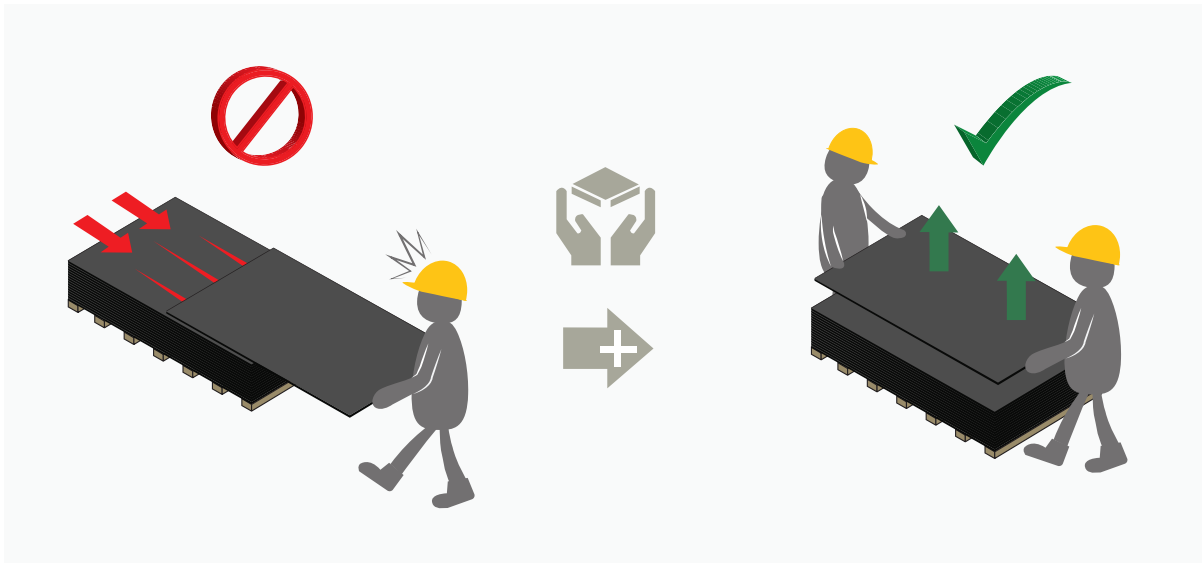

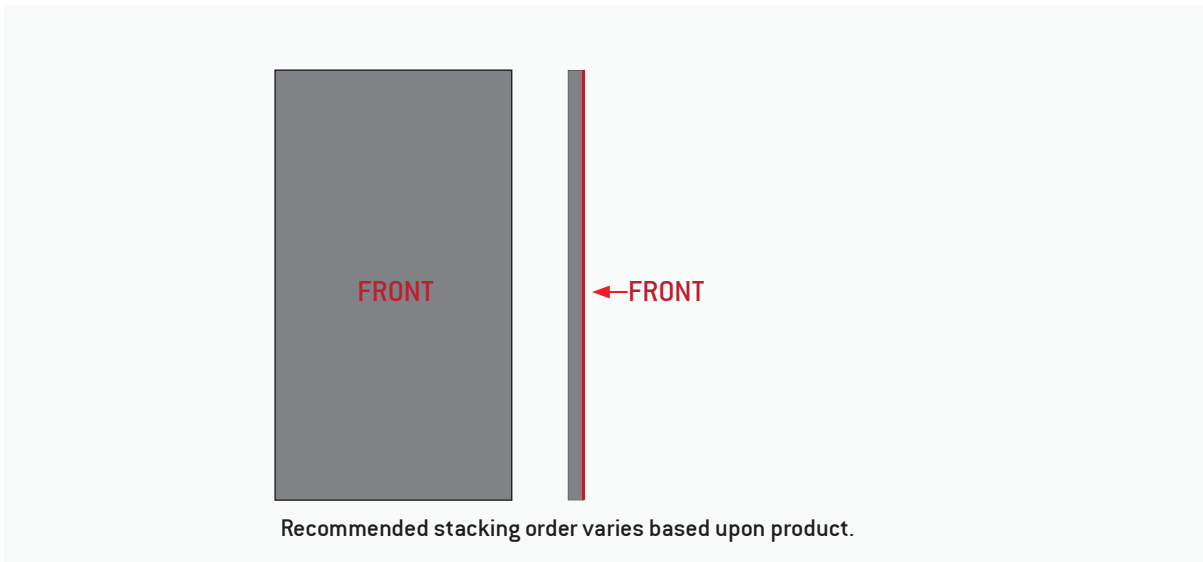
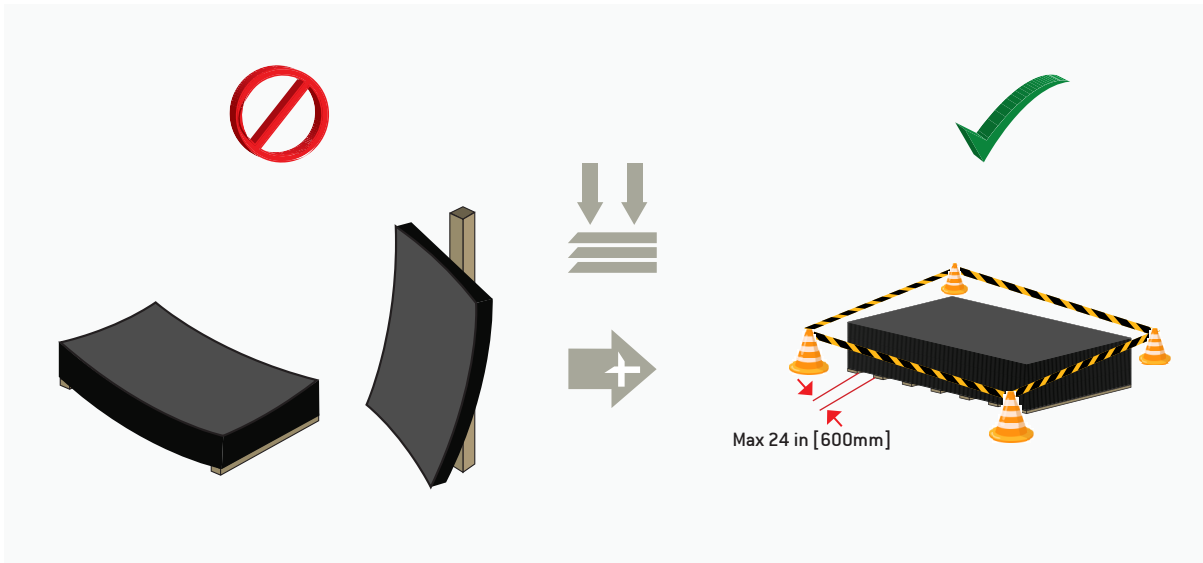

EQUITONE [natura], [natura] PRO, & [pictura]

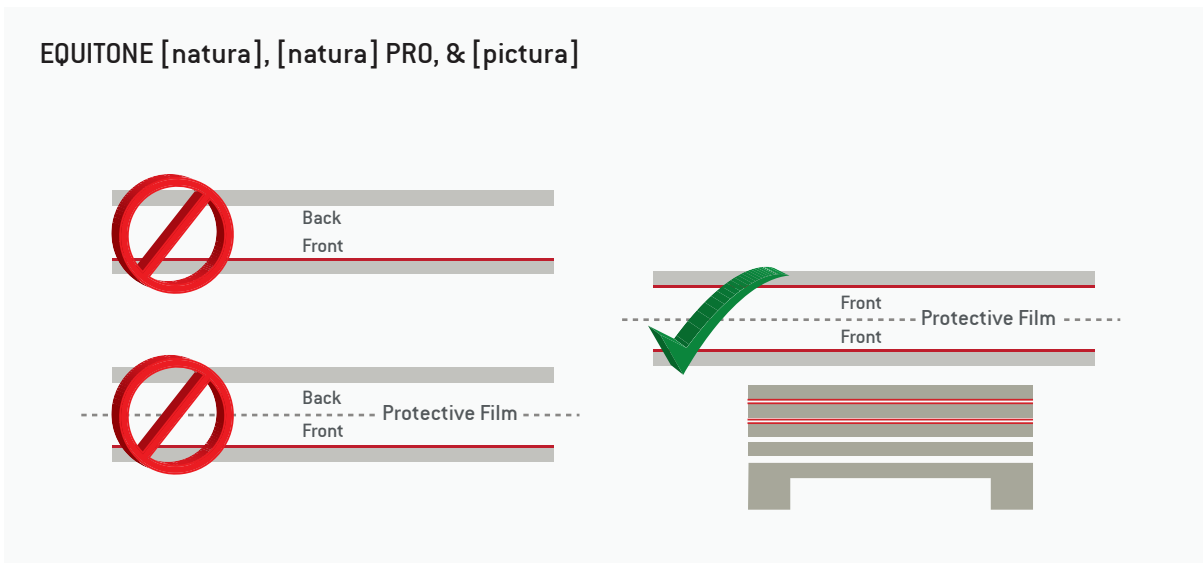

### EQUITONE [linea]

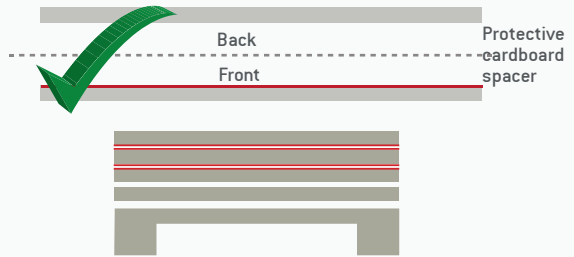
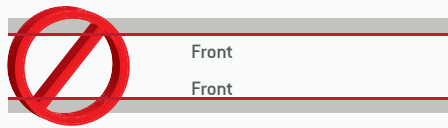
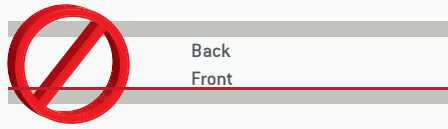

### EQUITONE [tectiva] & [lunara]

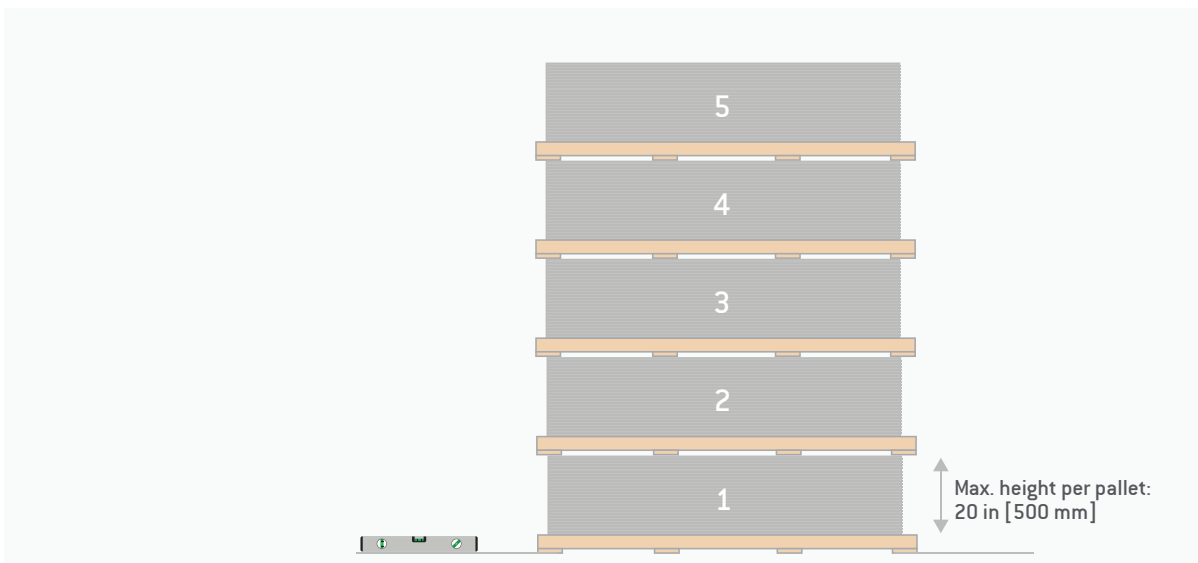
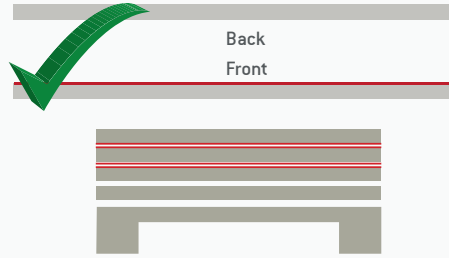
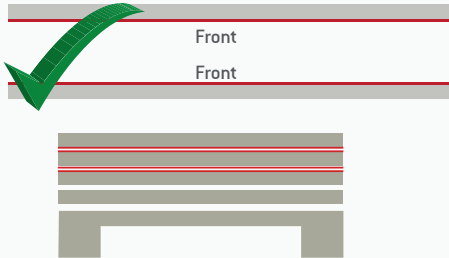

# PANEL CUTTING

## TOOLS

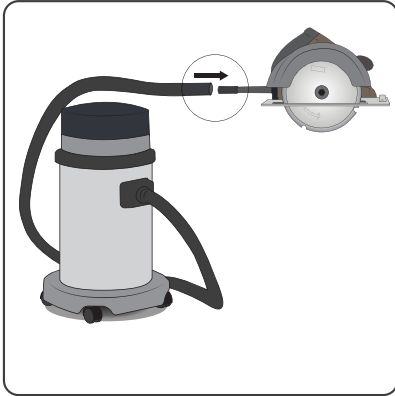

Dust extraction system

EQUITONE fiber cement saw blade

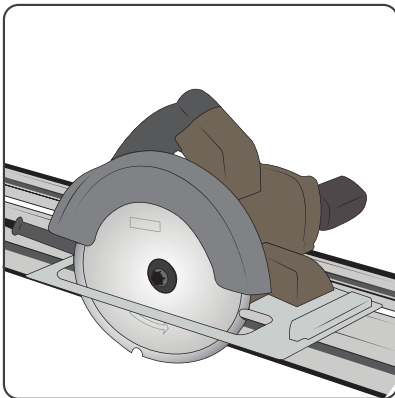
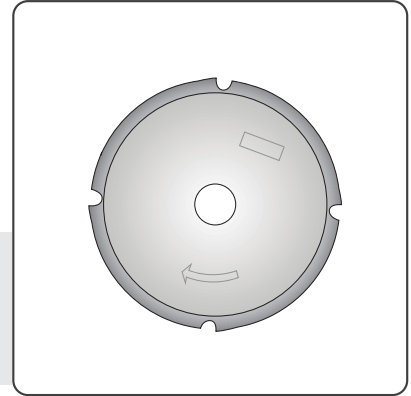

Circular saw & Guide rail

Styrofoam film blade

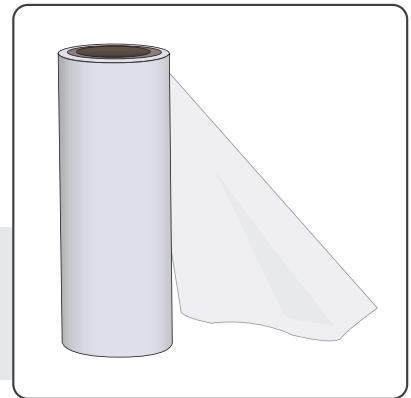

Stable Work Table With Sacrificial Board blade

# PANEL CUTTING

1

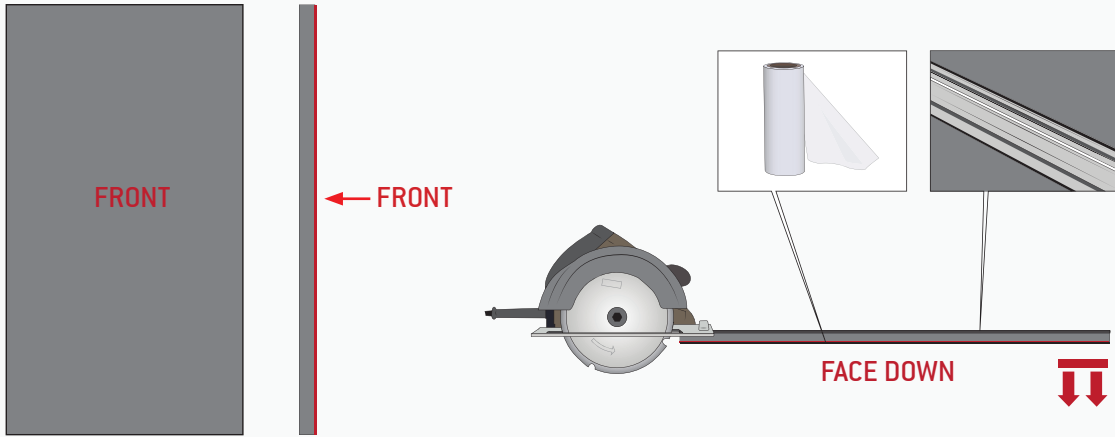

2

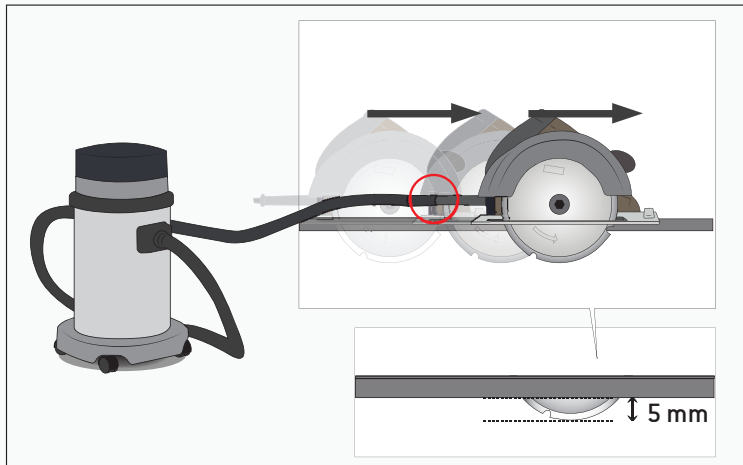
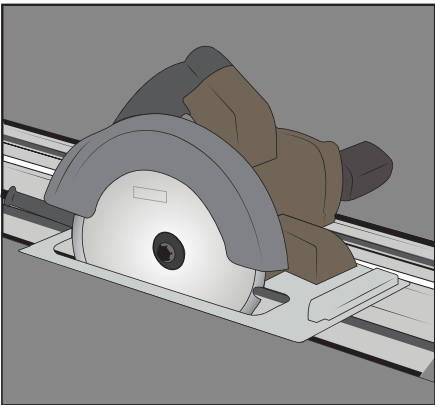

# PANEL EDGE TREATMENT

## TOOLS

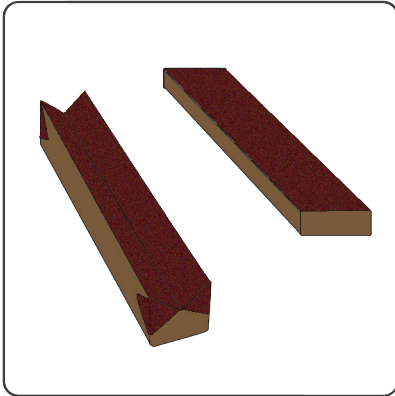

Sandpaper  
(80 Grit)



Soft bristle  
brush

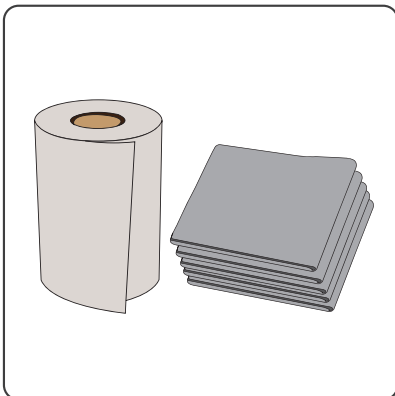

Micro fiber cloth,  
paper towel



LUKO edge sealer  
& applicator

\*For EQUITONE  
[natura] & [natura] PRO

# PANEL EDGE TREATMENT

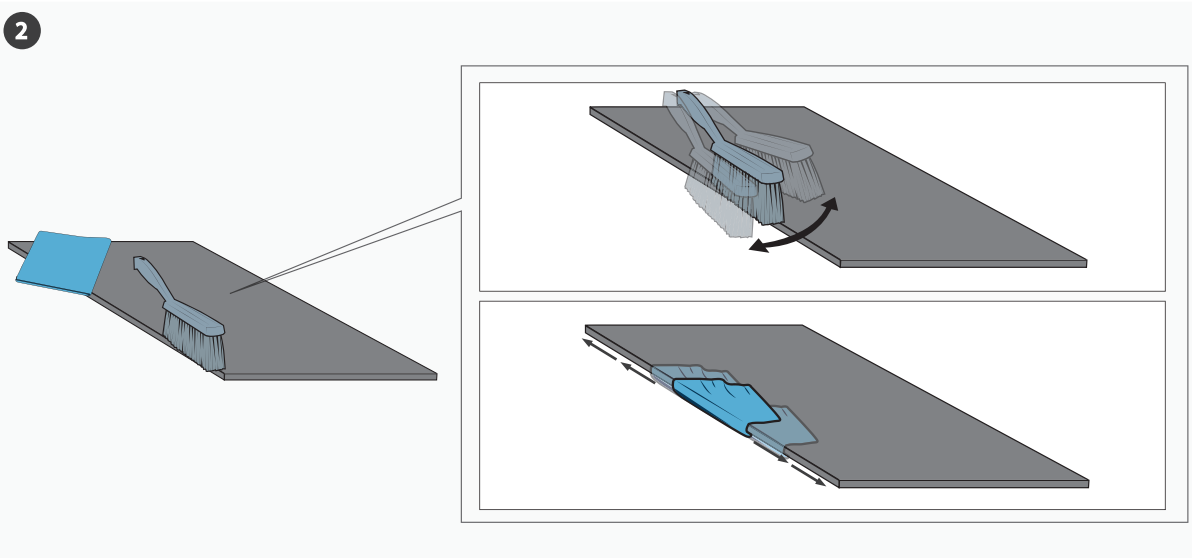
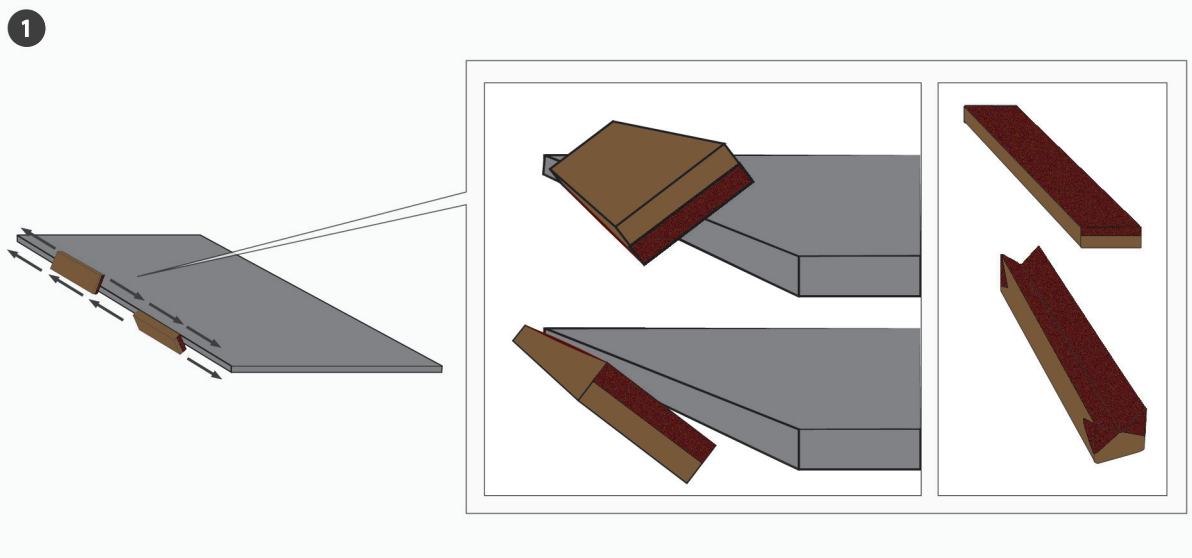

Steps 3 to 7: Only applicable to EQUITONE [natura] & [natura] PRO

3

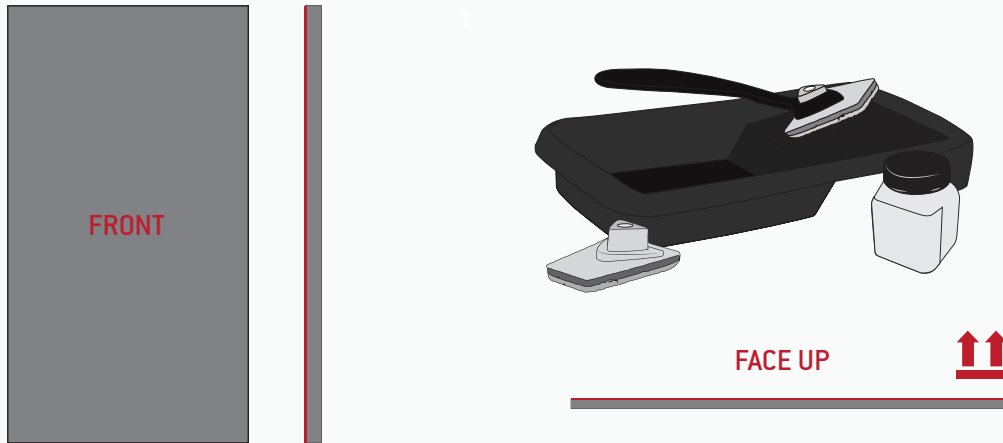

4

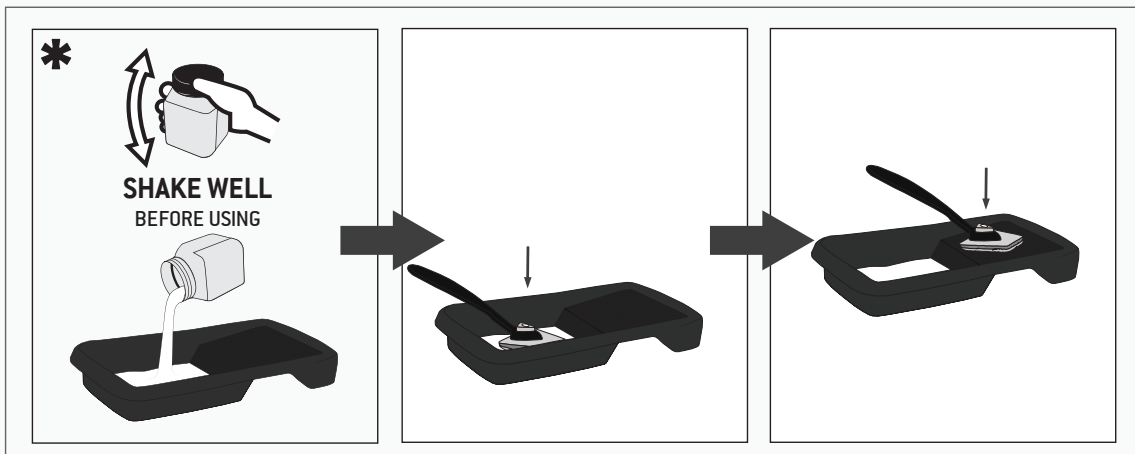

5

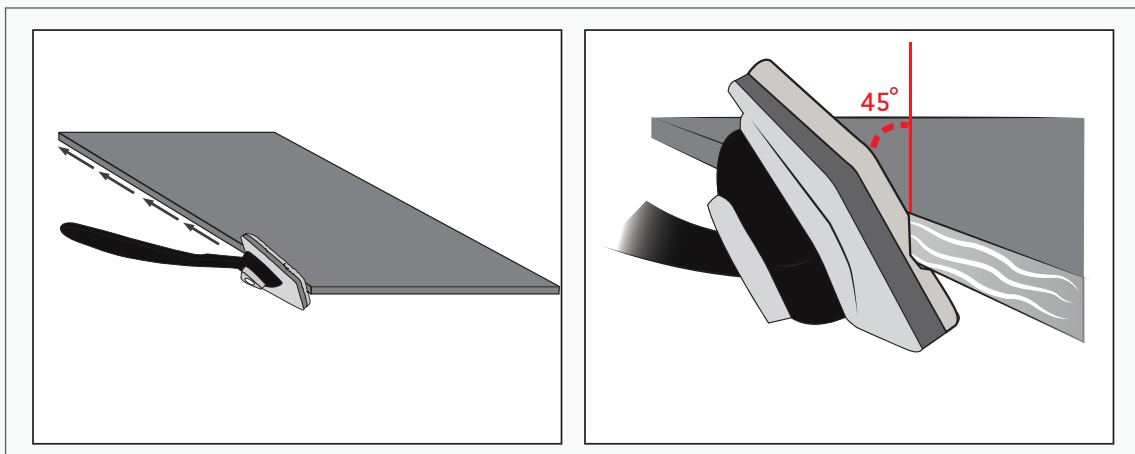

\*Pour only enough LUKO into the tray that can be used within 30 minutes.



6

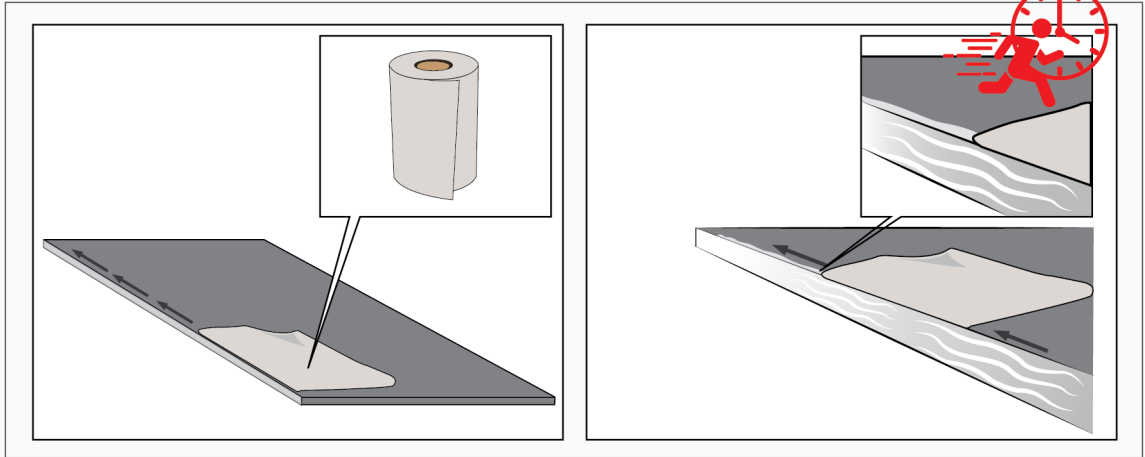

7

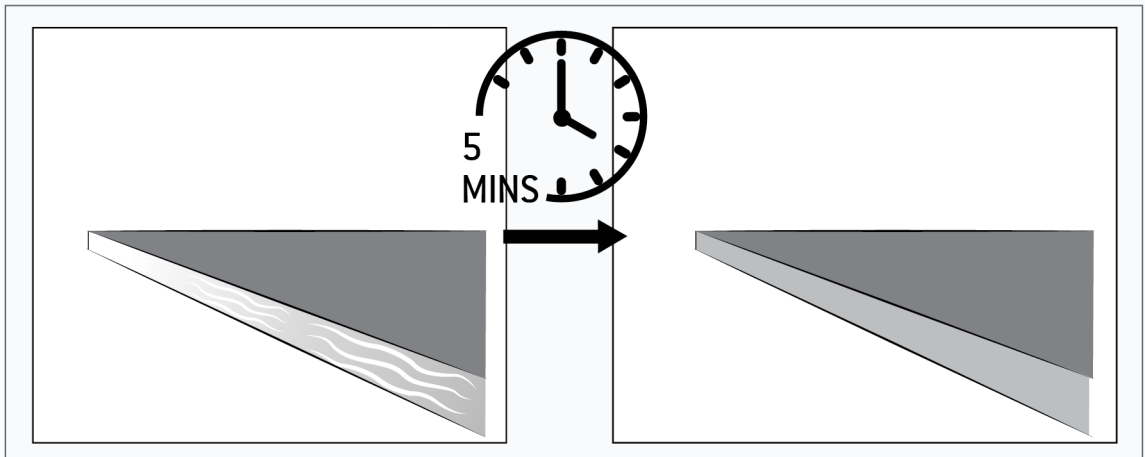

# PANEL DRILLING

## TOOLS

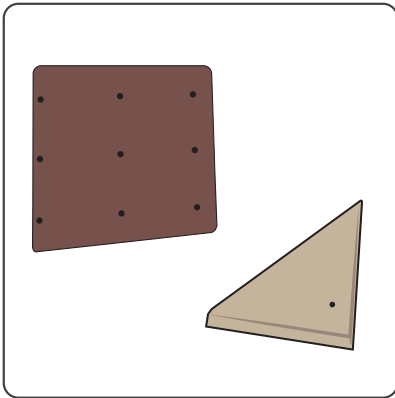

Hole Template  
(Optional)

EQUITONE Drill Bit  
11mm Diameter

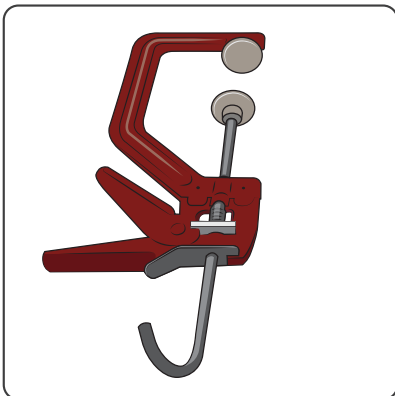

G Clamp  
(Optional)

EQUITONE [linea]  
milling tool  
11mm Diameter

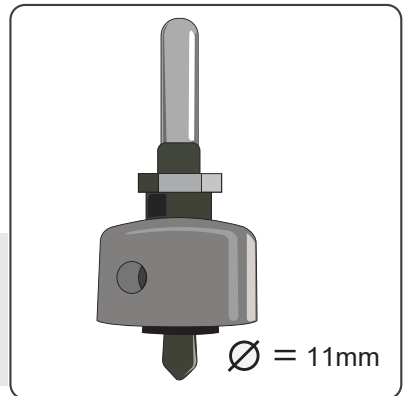

Stable Work Table  
With Sacrificial  
Board/Fiber Cement

Micro Fiber Towel  
& Brush

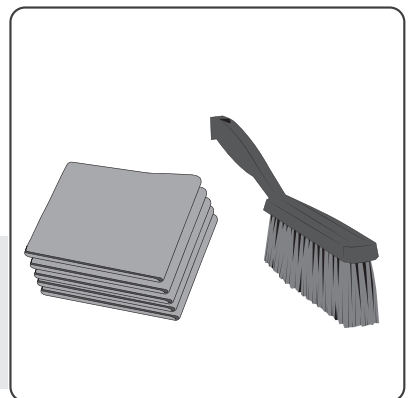

# PANEL DRILLING

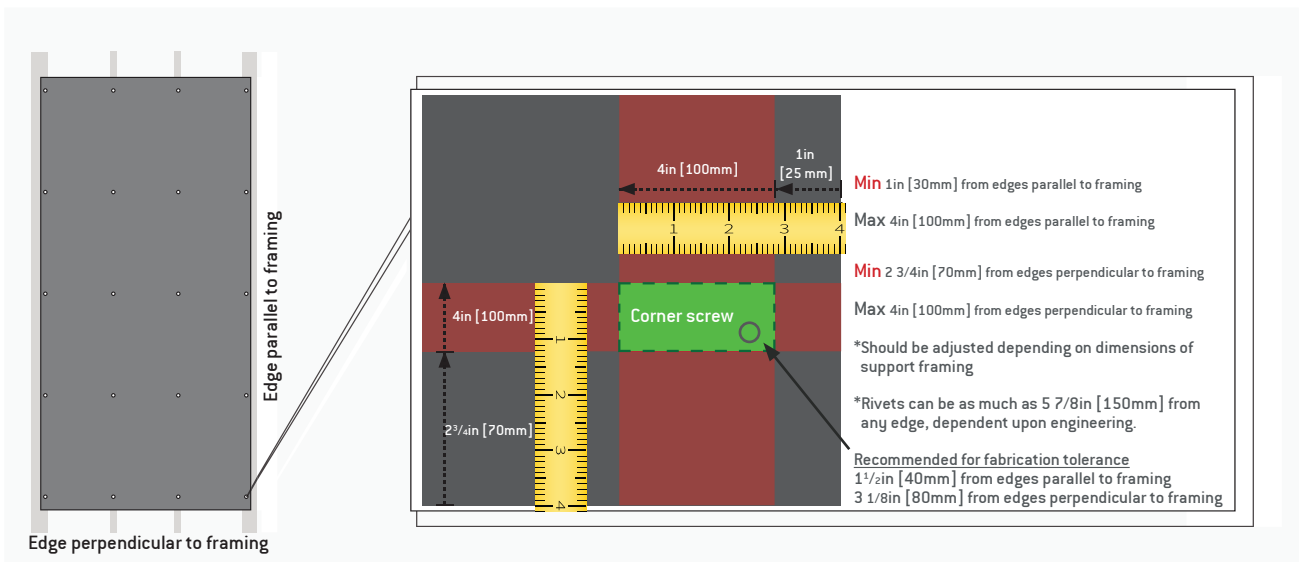
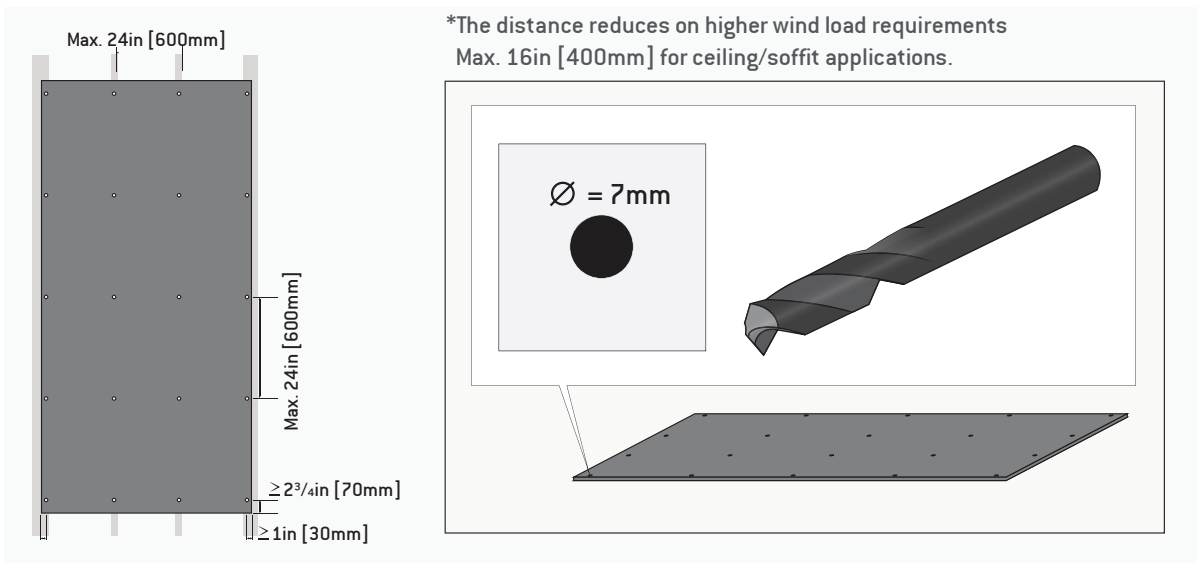
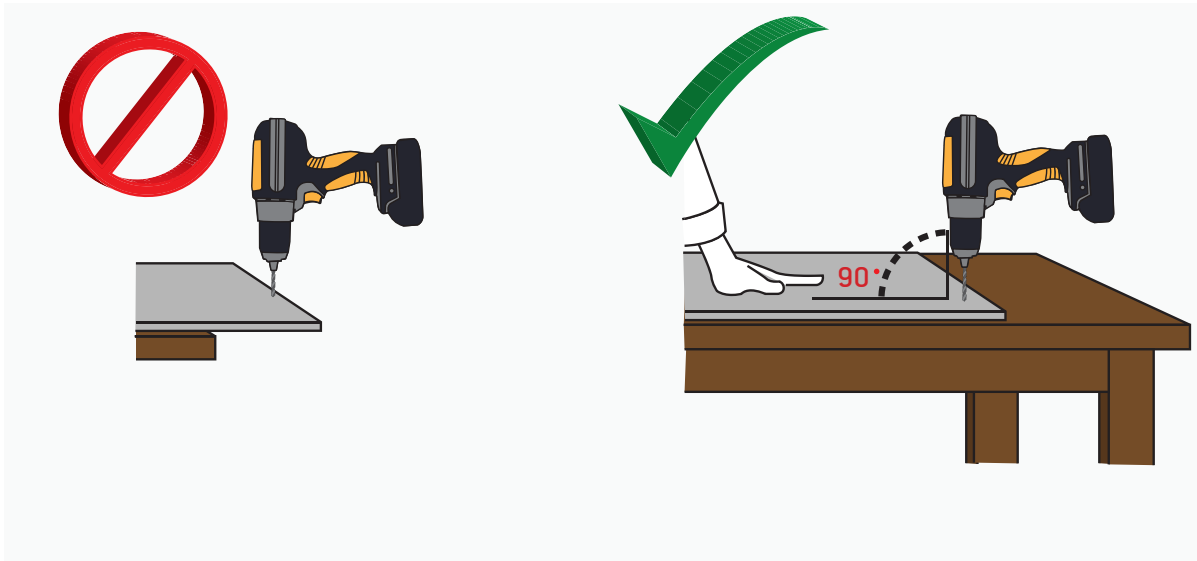

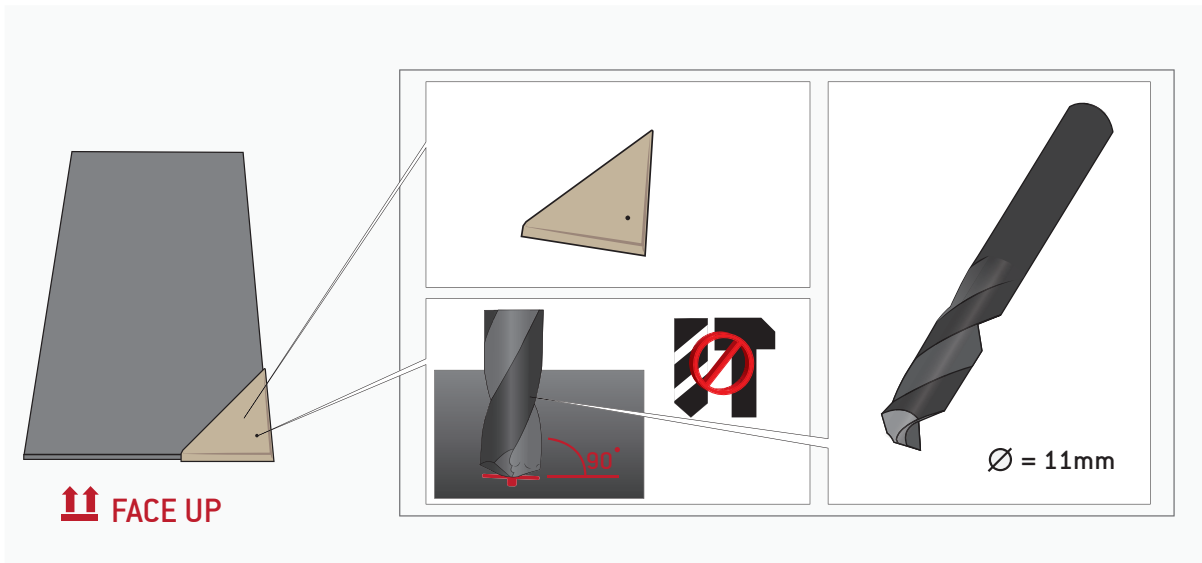

# PANEL DRILLING

EQUITONE [linea]

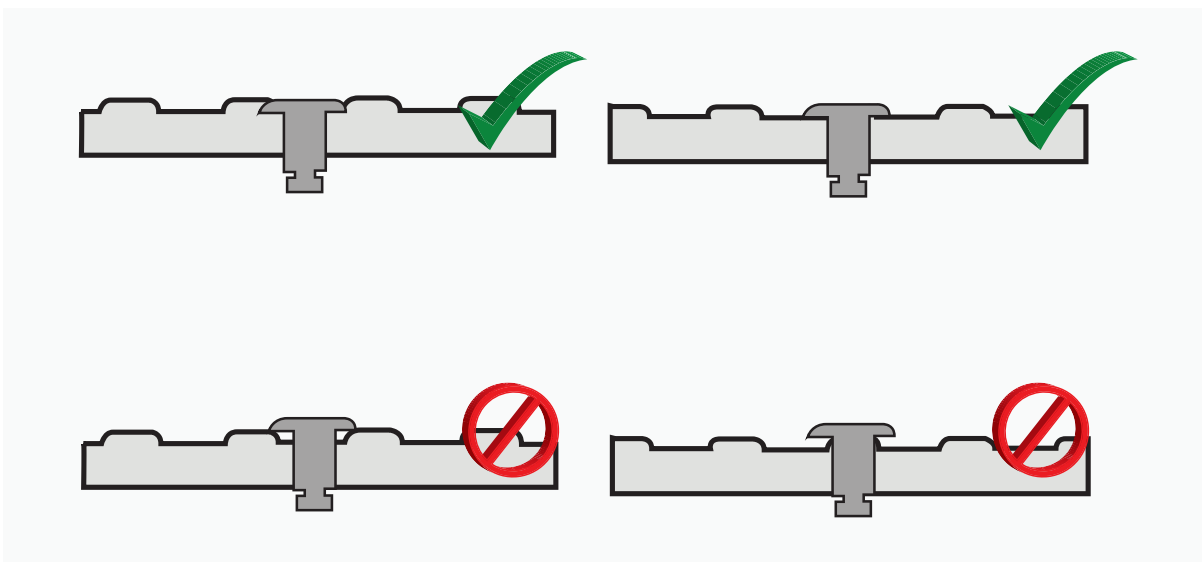
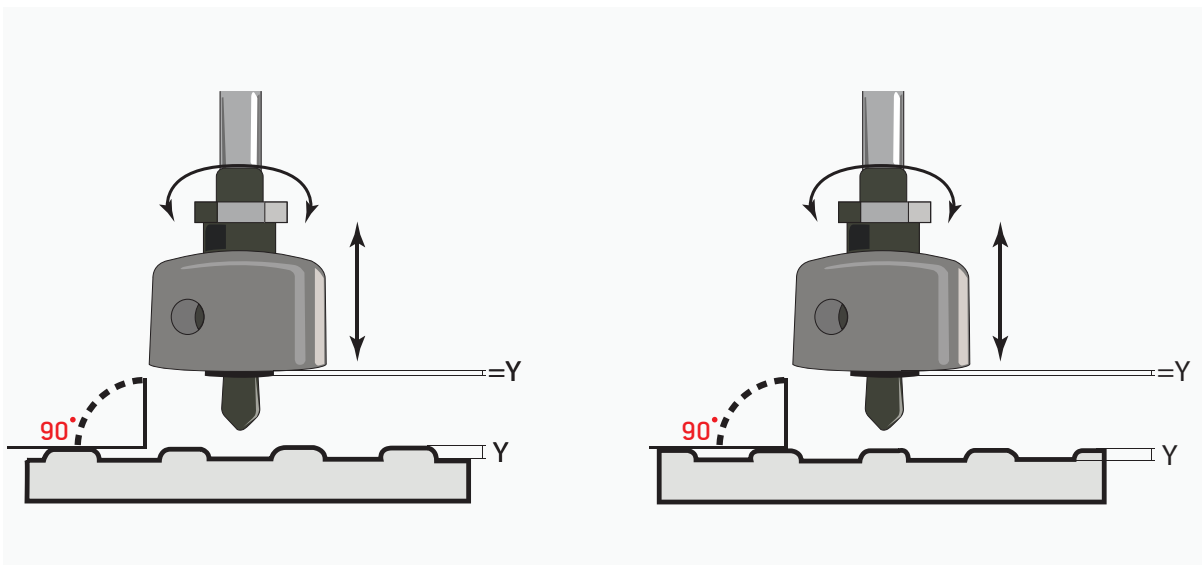
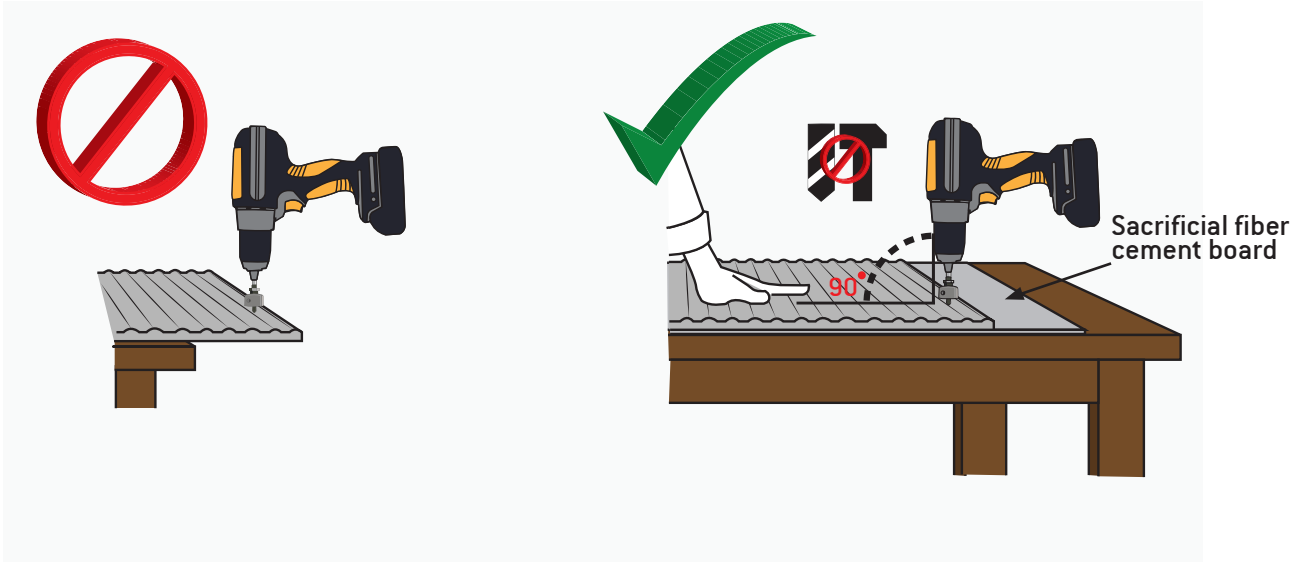

# CLEANING

## AFTER

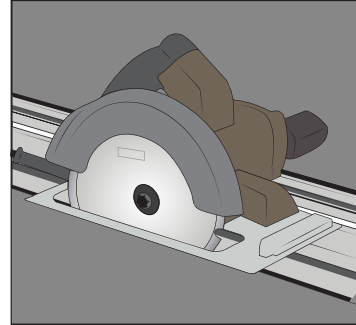
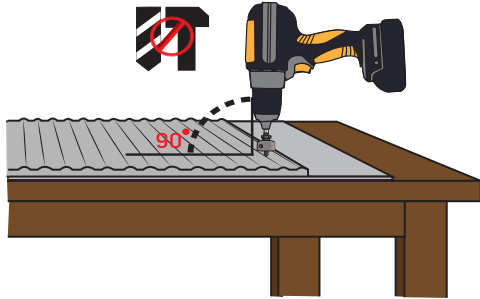

## DO

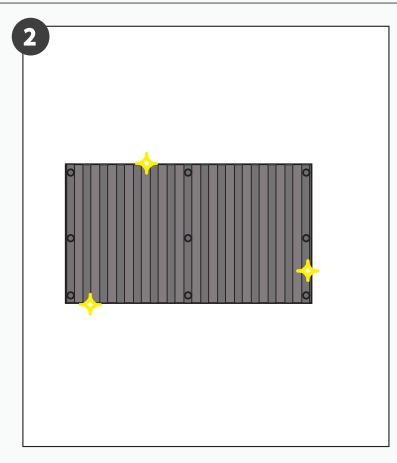
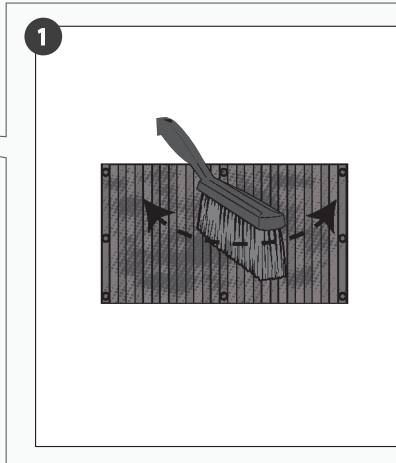
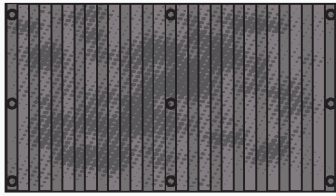

## OR

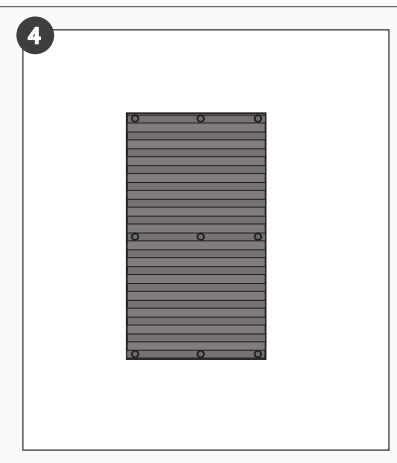
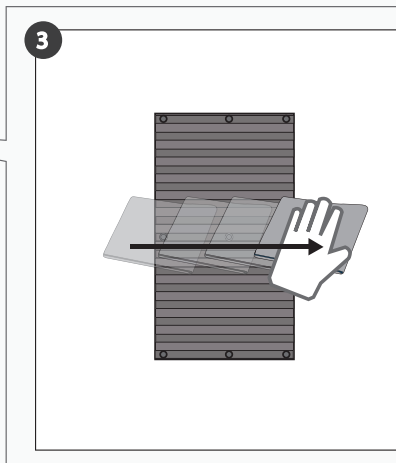
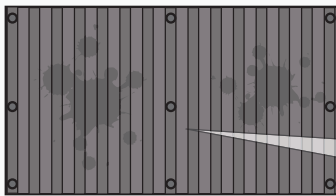

\*It is important to clean the panel after any drilling or cutting operation.

# UNI-RIVET FIXING

## TOOLS



Cordless Drill

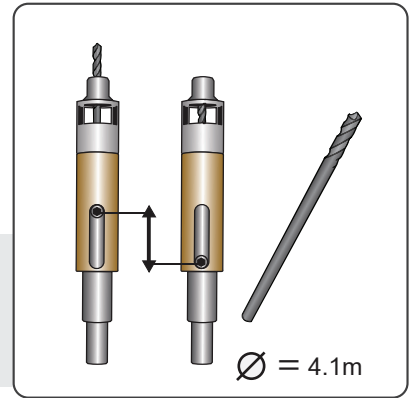

Centralizing Tool

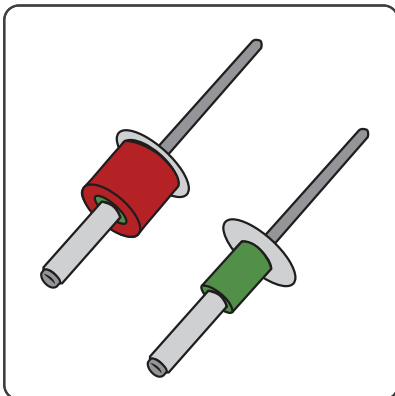

UNI-Rivets



Rivet Setting Tool

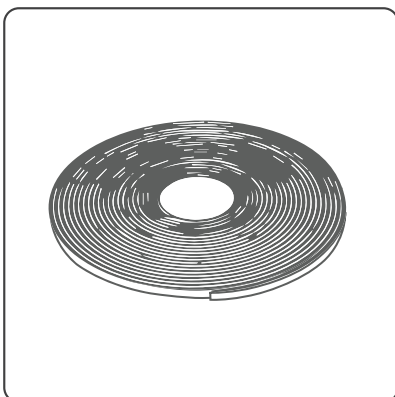

Foam Tape



Rivet Gun

# UNI-RIVET FIXING

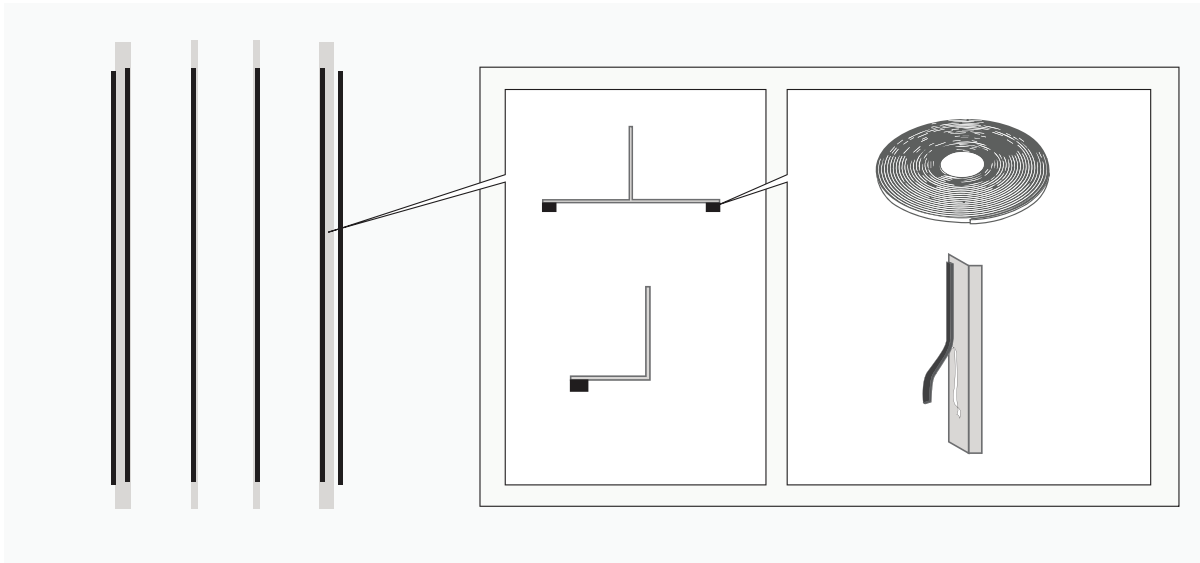

## JOINT PROFILE

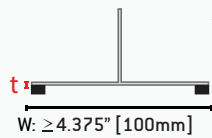

**t:**  
Galv. Steel  $\geq 17$  gauge [1.15mm]  
Aluminum  $\geq 13$  gauge [1.7mm]

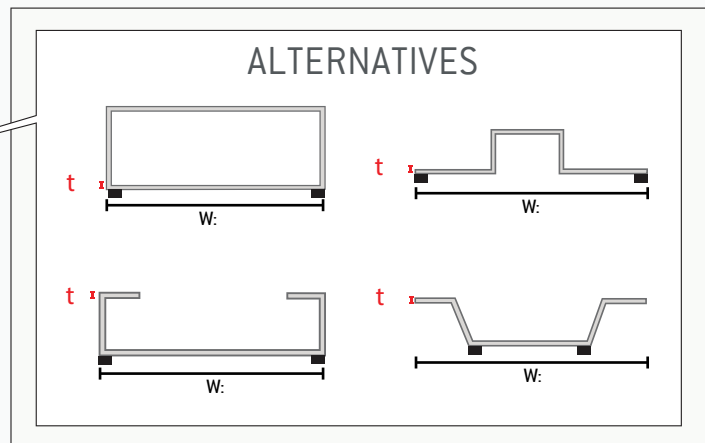

## INTERMEDIATE PROFILE

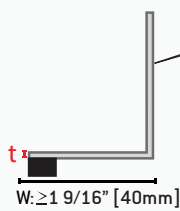

**t:**  
Galv. Steel  $\geq 17$  gauge [1.15mm]  
Aluminum  $\geq 13$  gauge [1.7mm]

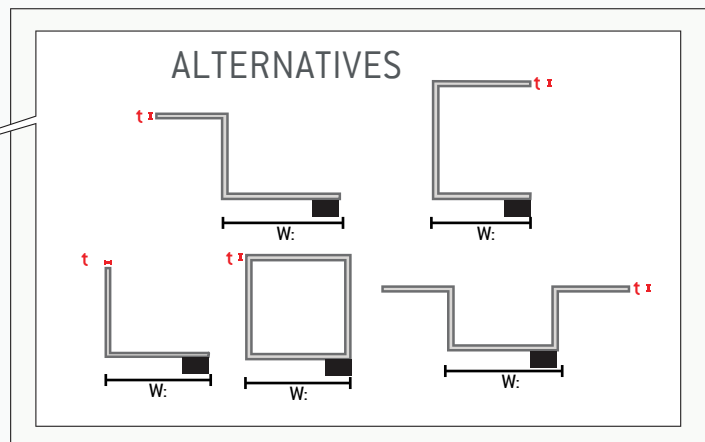



## Start with STOP (fixed) points

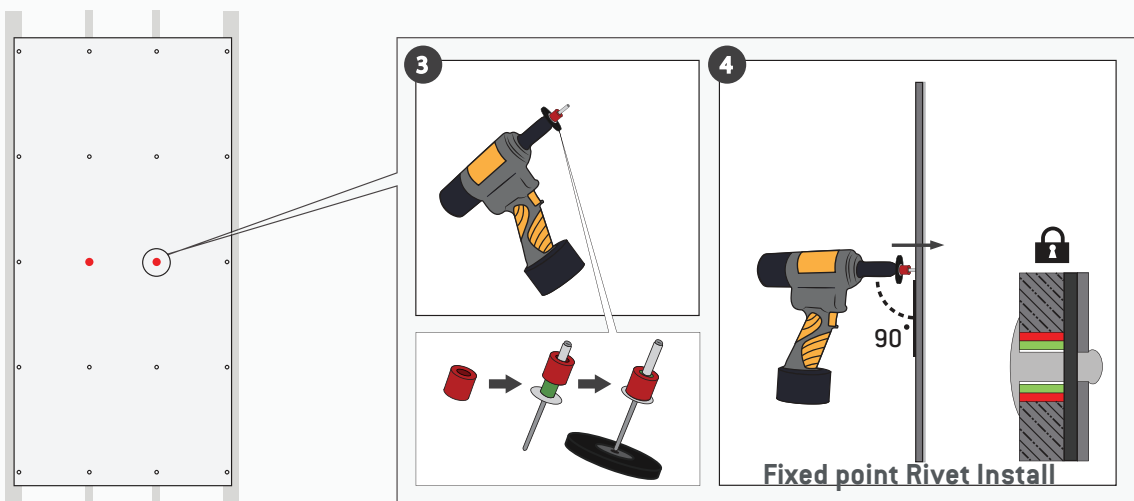
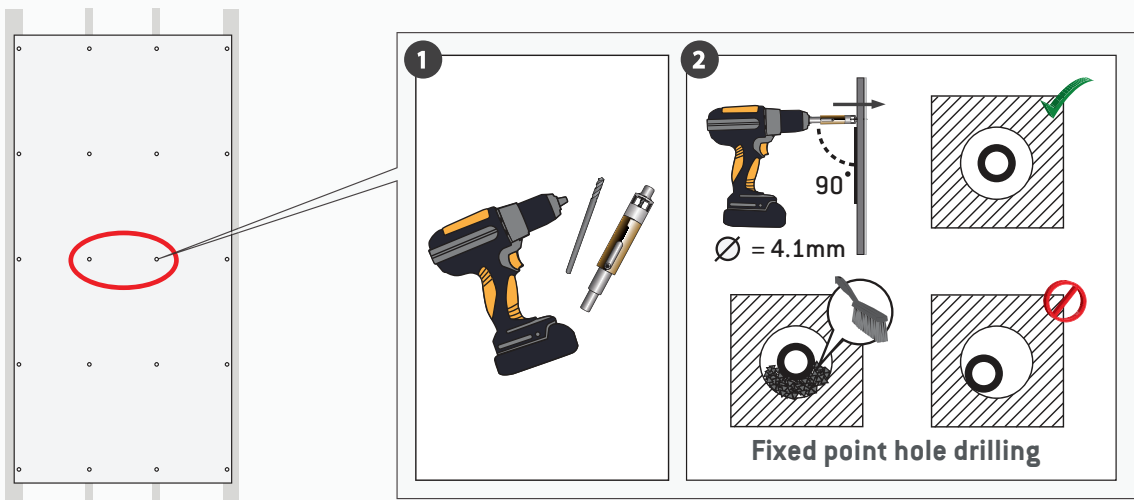

## Continue with GO (gliding) points

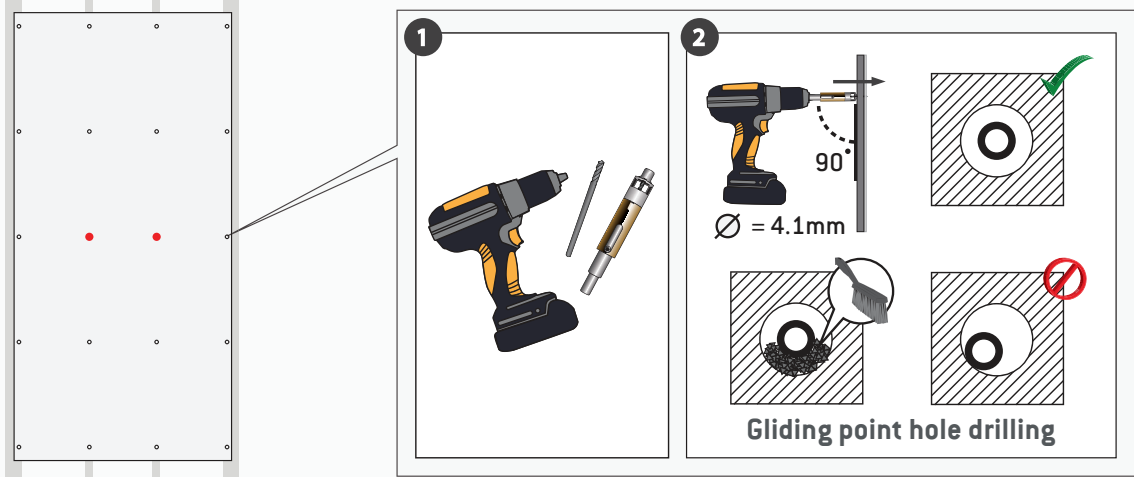

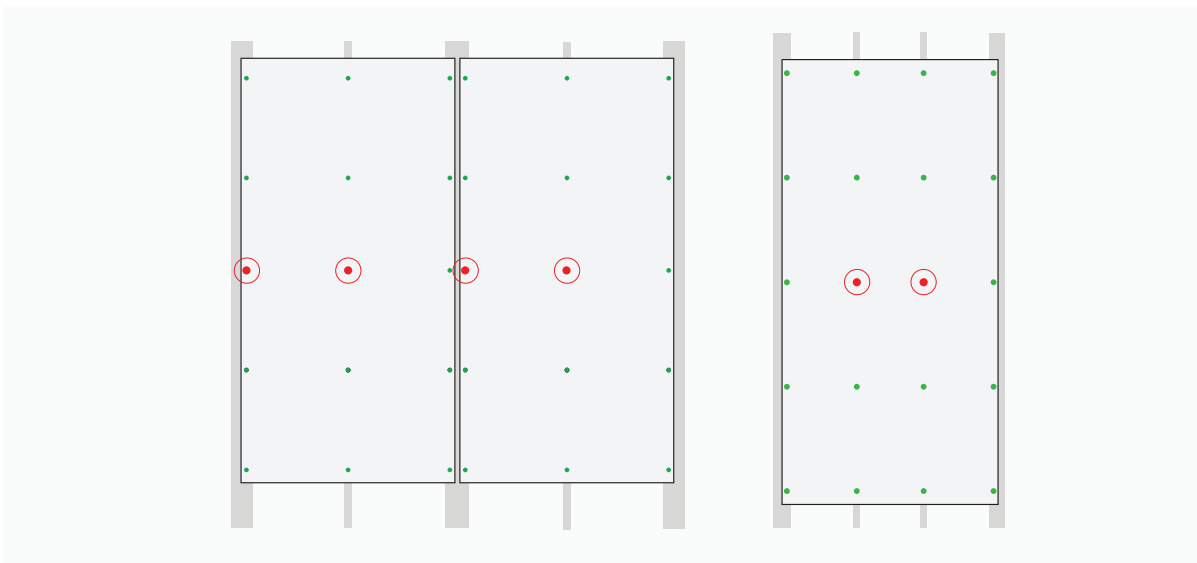
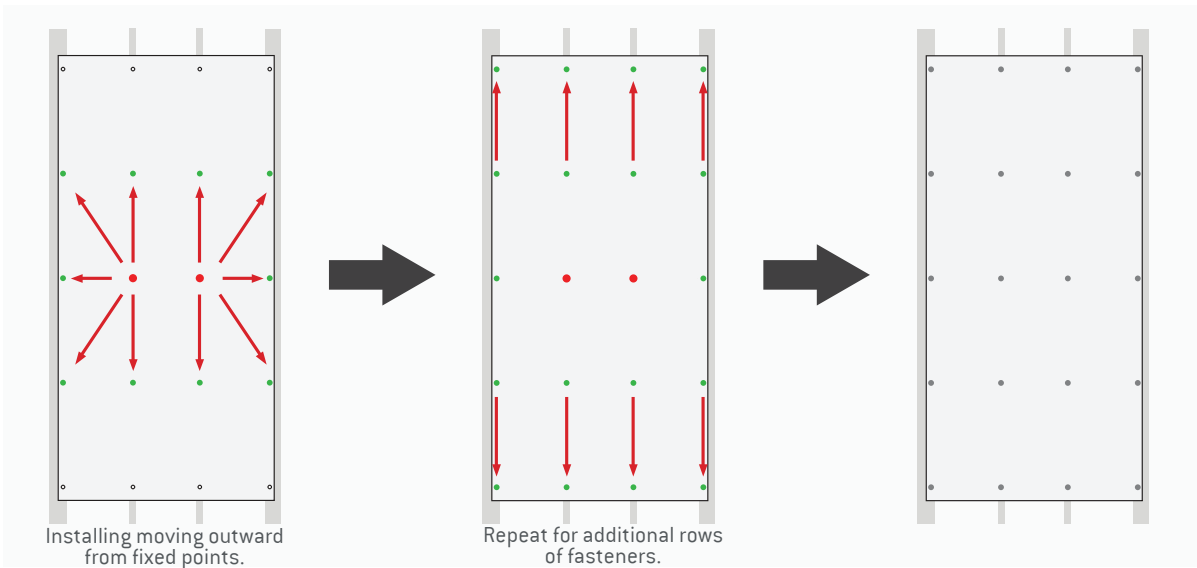
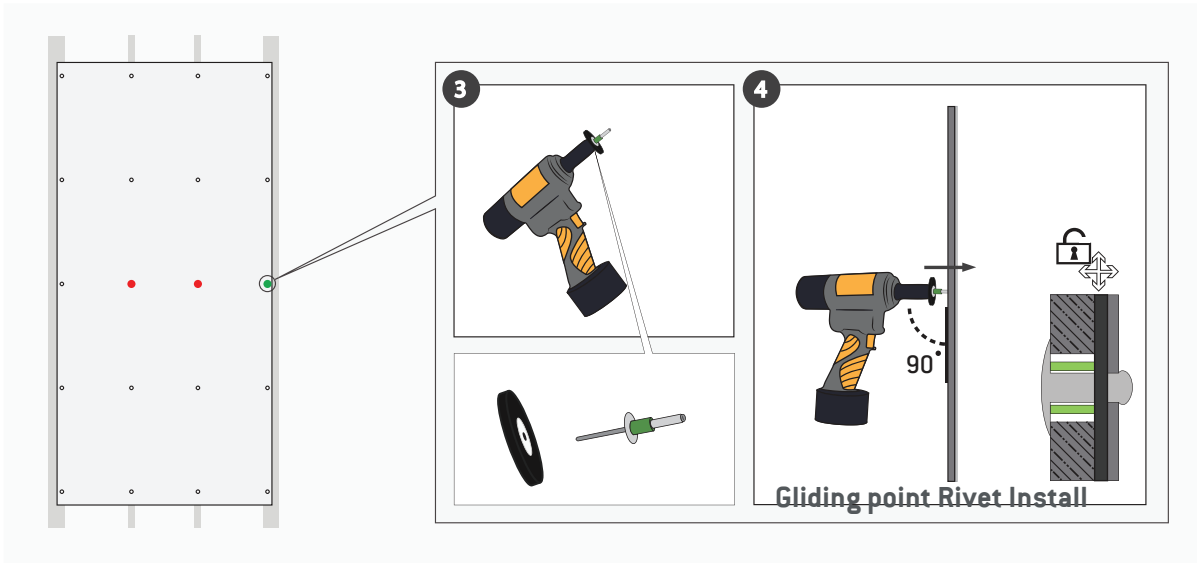

STOP (fixed) points Potential location

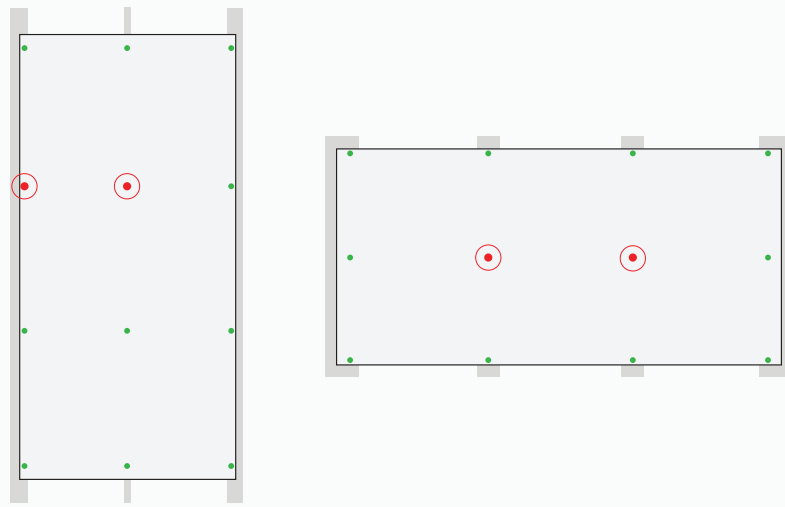

STOP (fixed) points Potential location

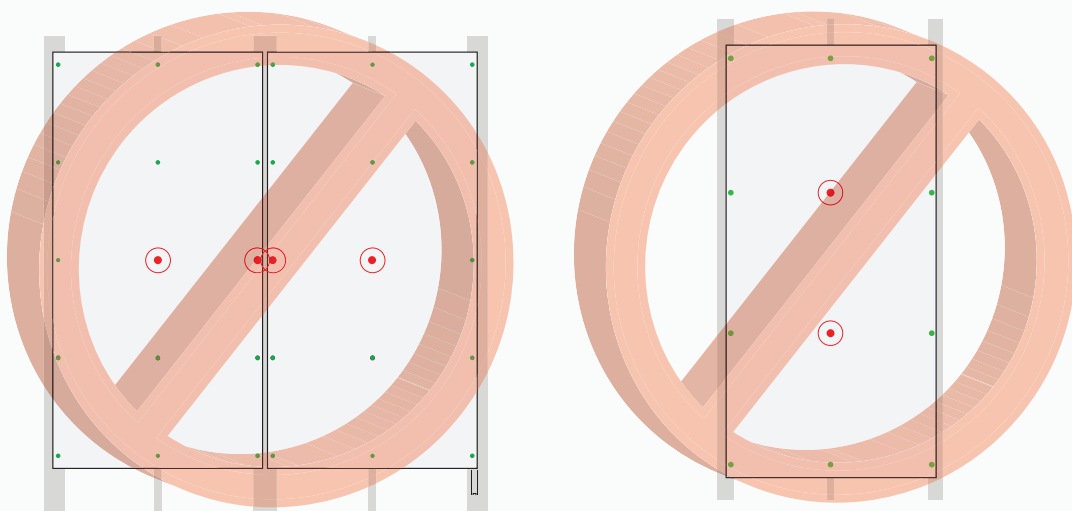
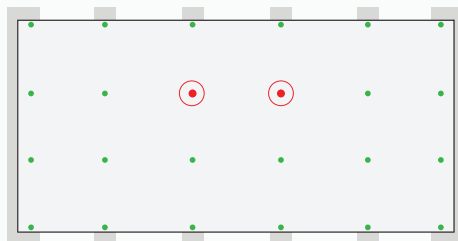

# VENTILATION

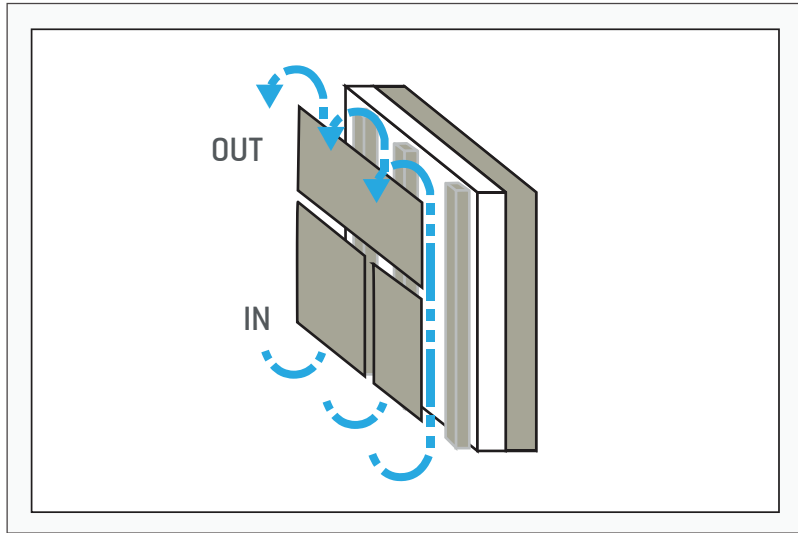

Minimum inlet and outlet size 3/8 in [10mm]\*

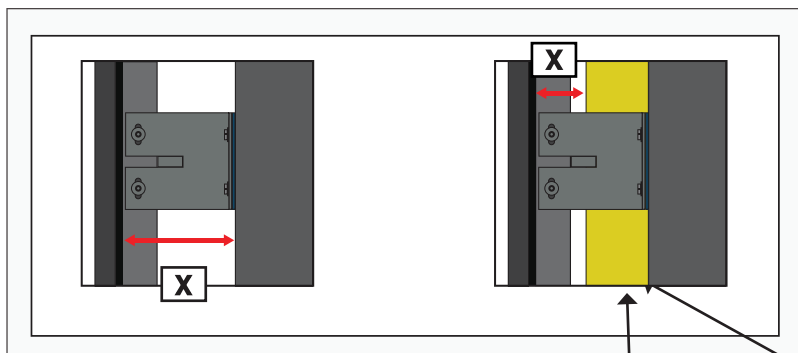

$X \geq 3/4$  in [20mm]\*\*  $Y \geq 2 3/8$  in [60mm]\*\*\*

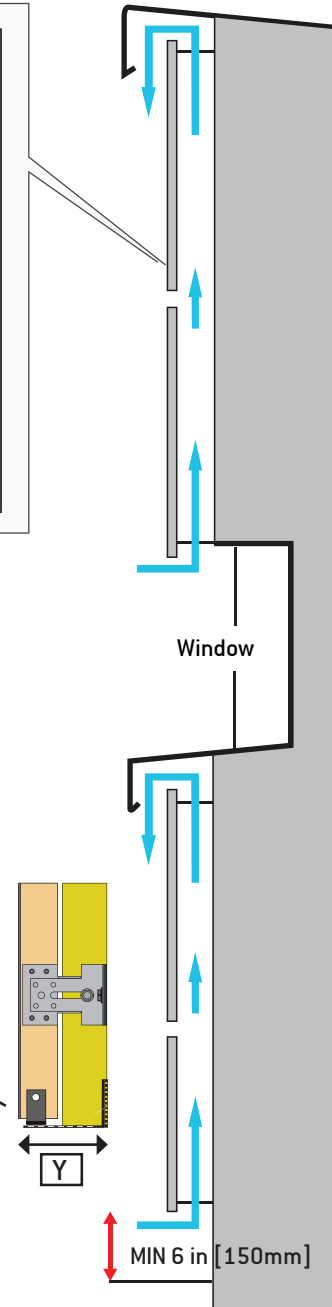

\* Inlet and outlet opening sizes should increase as the distance between them increases. Outlet openings should always be less than or equal to the inlet openings.  
 \*\*Cavity space X increases as the height of the facade & vertical distances IN & OUT increases  
 \*\*\*Closure width Y is dependent upon the volume of air the perforations allow. A 33% perforated profile should be 3x wider than the recommended inlet size.  
 \*\*\*\*Refer to other relevant EQUITONE technical documentation for more details regarding minimum sizing for ventilation.

# INSTALLATION

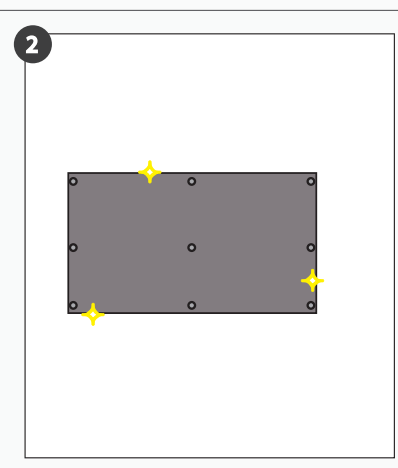
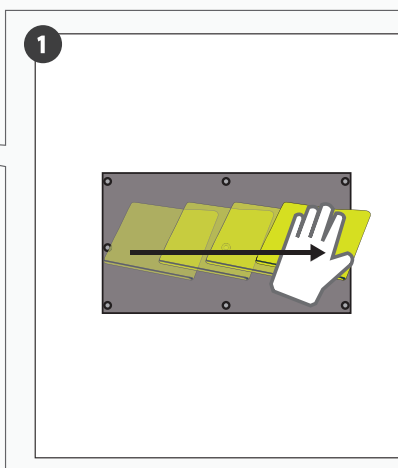
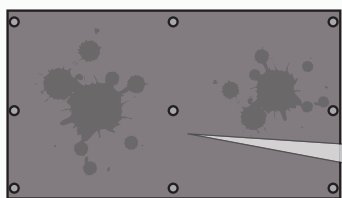
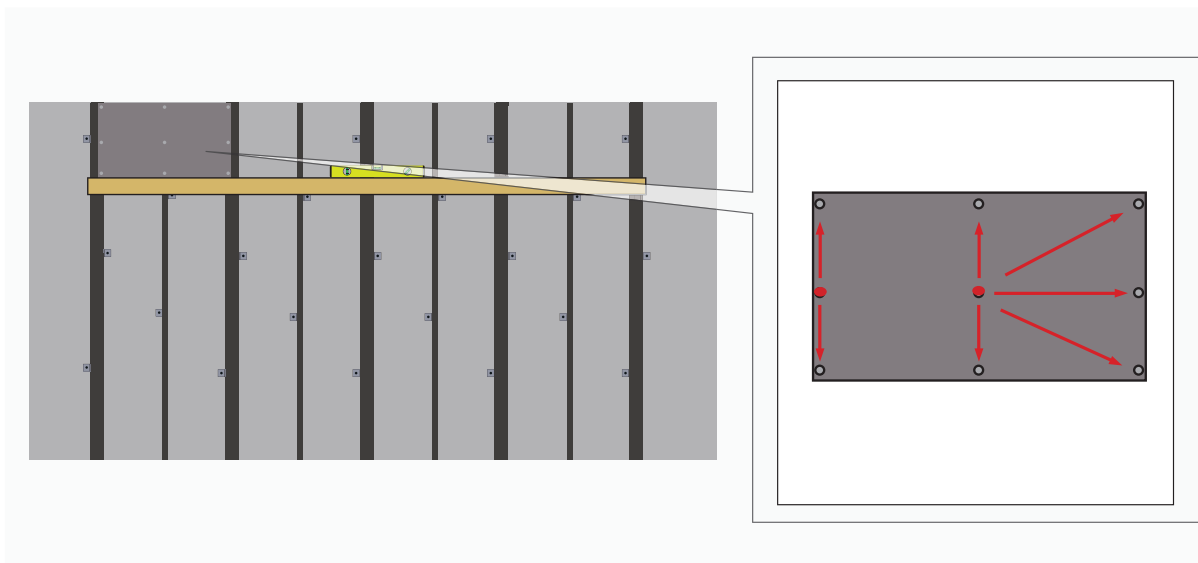
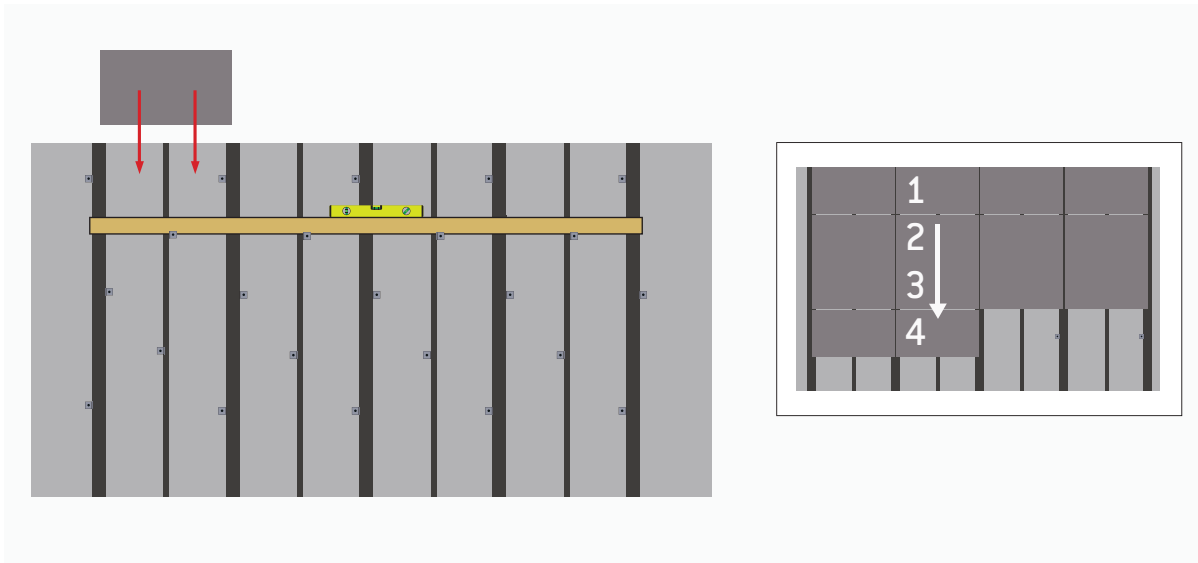

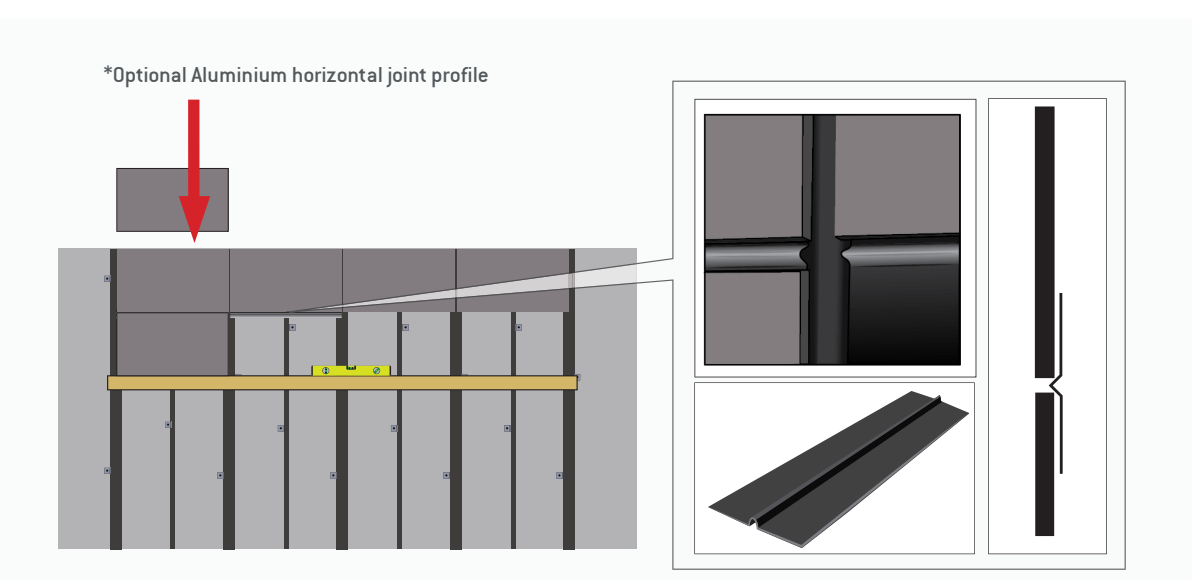
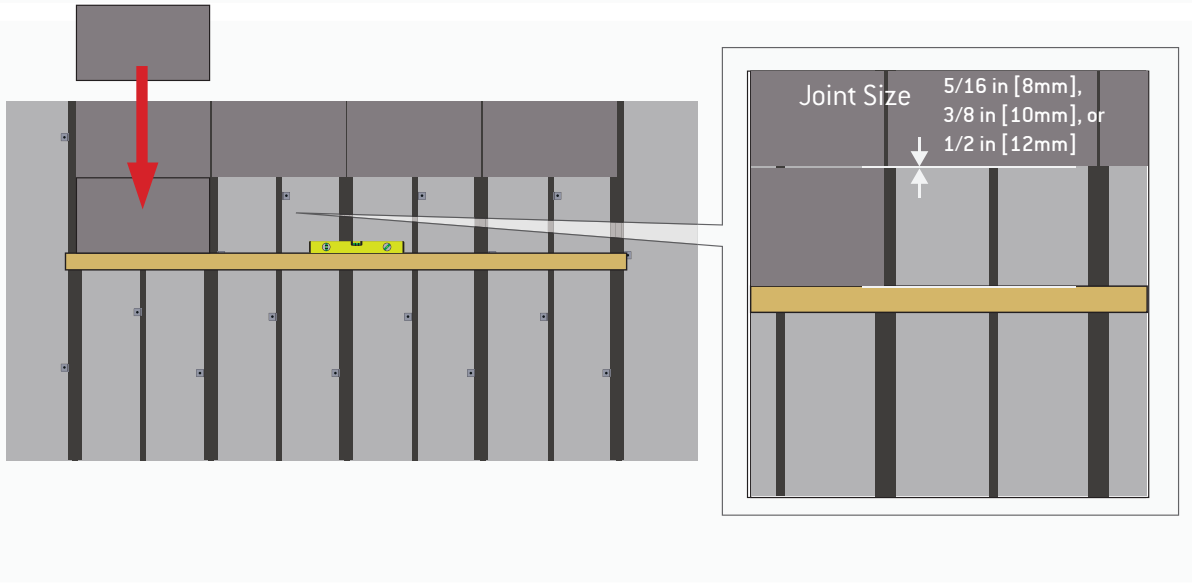
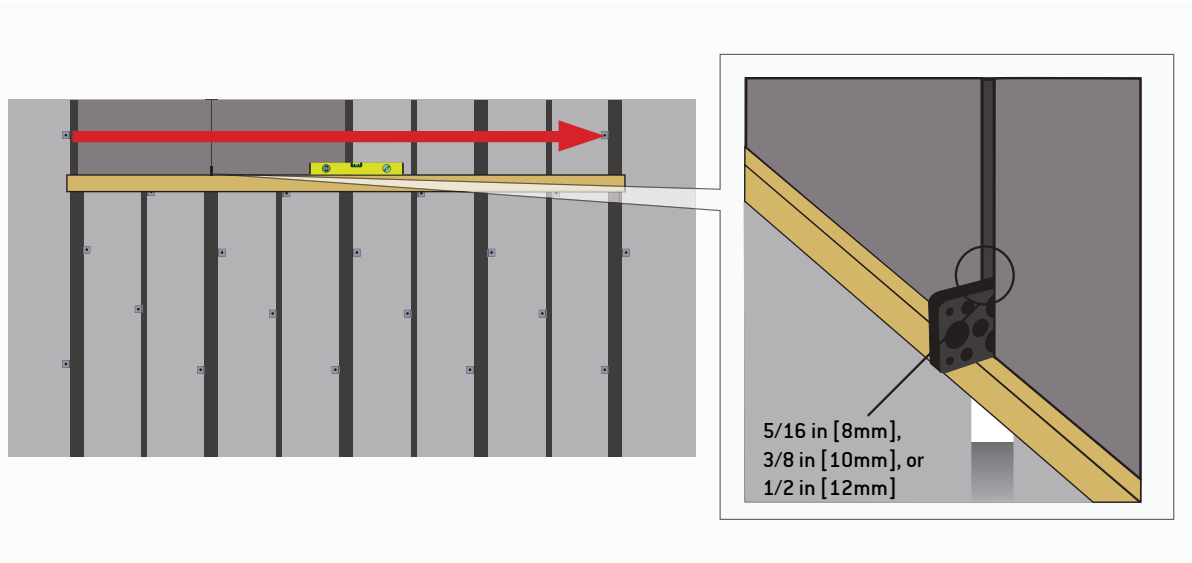

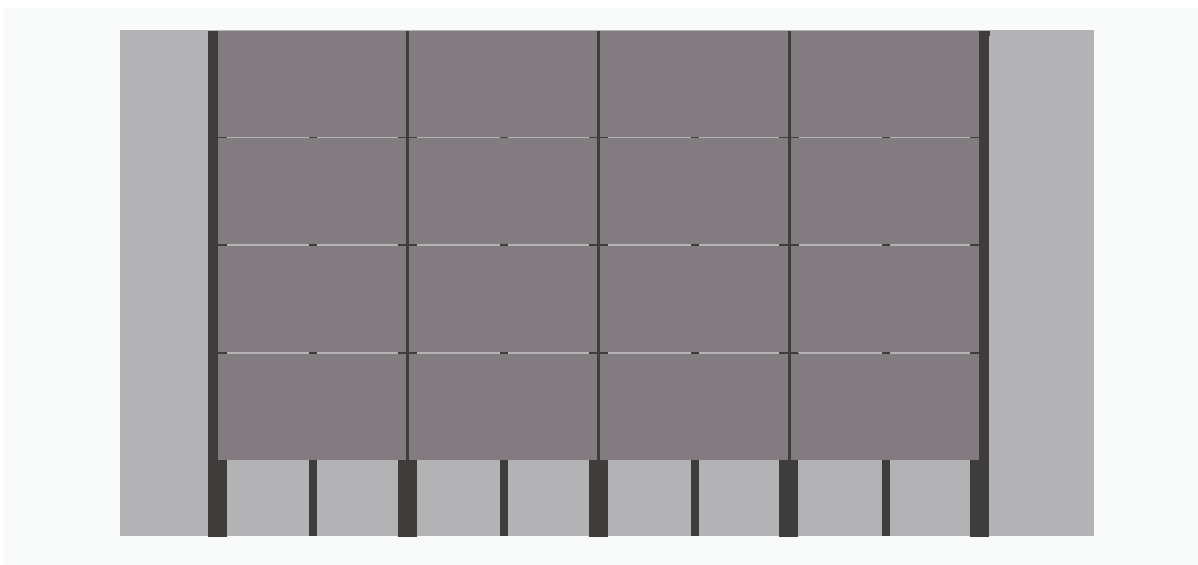
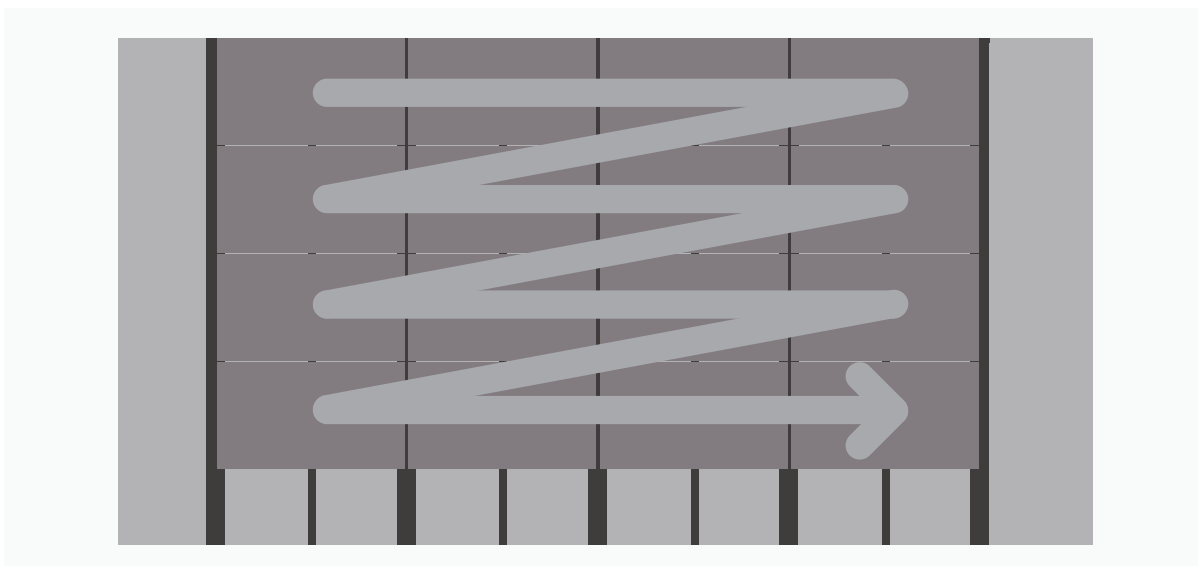



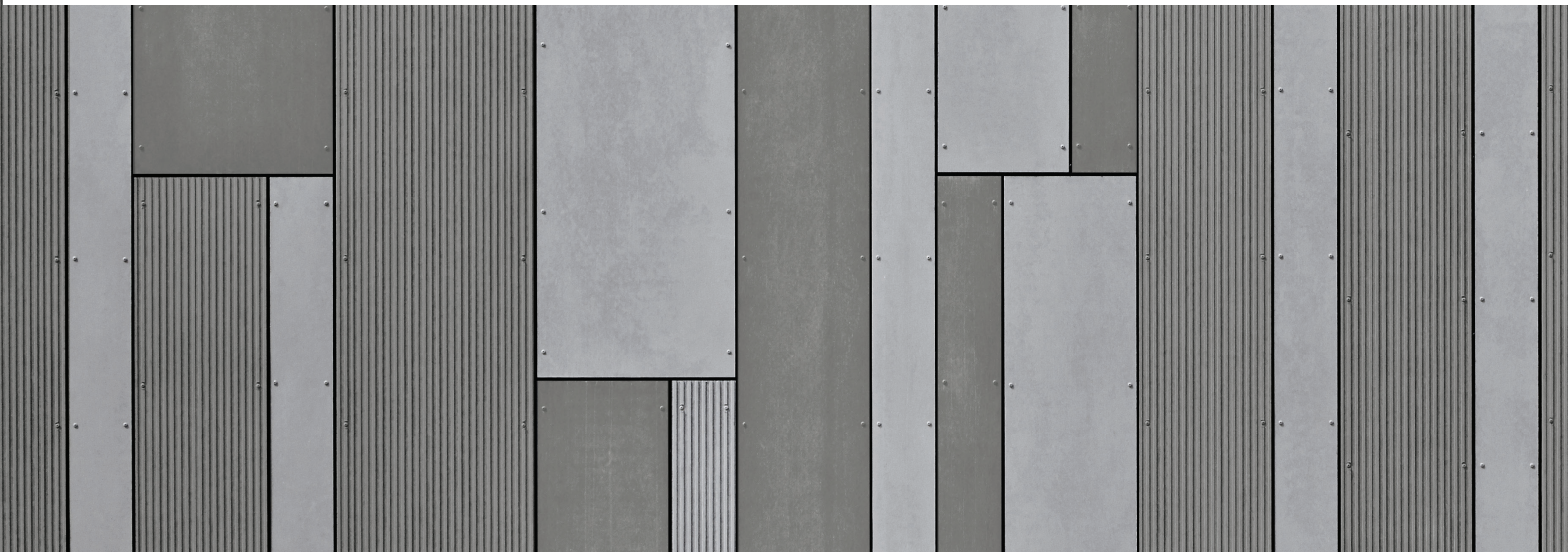

 **EQUITONE**  
Fibre cement facade materials



[equitone.com](http://equitone.com)

Follow us:

-  [equitone facade](#)
-  [equitone facade](#)

